

Key Features

- Excellent infrared light distribution
- High-quality low-noise video
- Compact design
- 84 infrared LED illuminators
- 940 nm or 850 nm options
- Up to 35ft. (10.7m) performance in total darkness
- Wide angle LED option for small room installations
- LEXAN windows
- Internal pan-tilt device for slight camera adjustments
- Various 1/3" CCD's available
- IR intensity adjustable
- Photocell controlled
- Easy lens access
- Painted finish
- Vandal resistant screws
- Plug and Play installation

Product Description

Extreme CCTV's modular infrared LED boards are integrated to the EX37 Wall Camera to achieve night-time surveillance in complete darkness up to 35 feet (10.7 m). The design allows for better infrared spread and intensity. Separate windows for the camera lens and the LEDs allow for minimum light interference and greater installation versatility.

The smooth compact housing allows for neat installations to public buildings such as hospitals and schools. Eighty-four (84) infrared LEDs provide light energy at 850nm or 940nm. A voltage and current control board controls LED light intensity while ensuring long life. A photocell allows automatic on/off infrared operation. Lenses are interchangeable. Cameras can be adjusted slightly for pan and tilt. Pre-harnessed wiring with connectors make for easy plug and play operation in 12 VDC or 24 VAC.

The Mechanical Filter Series EX37M and EX37MX allows for accurate surveillance with color-by-day and infrared supported mono-by-night to maximize video information.

Product Image

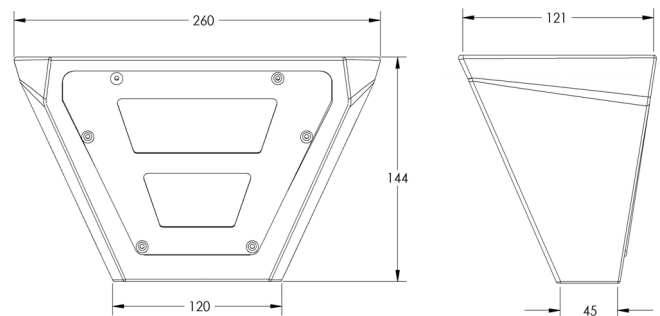

Applications

- Prisons
- Hospitals
- Psychiatric facilities
- Detention centers
- Offices
- Schools

Certification / Compliance

CSA C22.2 No 0-M1991	General Electrical Rqts, Part II
CSA C22.2 No 1-M94	Audio, Video, & Similar Equip
CSA C22.2 No 94-M91	Special Purpose Enclosures
UL Std No 50	Enclosures for Electrical Equip
UL Std No 2044	Commercial CCTV Equipment Applic Health Care Facility Rqts

Dealer / Distributor



Corporate Headquarters
Extreme CCTV Inc
TF: 1 888 409 2288
T: +1 604 420 7711
F: +1 604 420 3300
E: Sales@ExtremeCCTV.com
www.ExtremeCCTV.com



European Operation
Derwent Systems Ltd
A Division of Extreme CCTV (UK) Ltd
T: +44 (0) 1670 730 187
F: +44 (0) 1670 730 188
E: SalesUK@DerwentCCTV.com
www.DerwentCCTV.com

Specifications: Night Vision Camera with Photocell

	EX37N High-Res Monochrome	EX37NX Enhanced Night Vision	EX37MNX Mech Filter Day/Night, Color/Mono
CCD	S3 High Resolution Monochrome	SX3 Night-Time Sensor	MX4 with MFP Technology
Image Sensor	1/3" Sony SuperHAD	1/3" LXR CCD	1/3" LXR CCD
Effective Pixels NTSC	768 (H) x 494 (V)	510 (H) x 492 (V)	765 (H) x 494 (V)
Effective Pixels PAL	752 (H) x 582 (V)	500 (H) x 582 (V)	752 (H) x 582 (V)
Resolution	600 TVL	420 TVL	450 TVL color 570 TVL monochrome
Daytime Sensitivity	0.05 Lux @ F1.4	0.05 Lux @ F2	0.1 Lux with F1.4 lens
Night-time Sensitivity	0.0 Lux - works in total darkness	0.0 Lux - works in total darkness	0.0 Lux - works in total darkness
S/N Ratio	Greater than 48 dB	Greater than 50dB	Greater than 46dB (AGC off)
Fixed Lens Options	3.6mm / 4.3mm / 6.0mm / 8.0mm	3.6mm / 4.3mm / 6.0mm / 8.0mm	3.6mm / 4.3mm / 6.0mm / 8.0mm
Electronic Shutter	1/60 to 1/100,000 second		
Video Output	1V p-p, 75 Ω, NTSC (PAL optional)		
LEDs	High efficiency array, 850nm or 940nm		
Number of LEDs	84		
Photocell	Automatic, sensitivity adjustable		
Achievable Distance	35ft (10.7m) in total darkness		
Voltage	12VDC or 24VAC		
Power Consumption	800 mA @ 12VDC (9.6W)		
Operational Range	-30°C to +35°C (-22°F to +95°F)		
Construction	Steel, removable front panel with security screws		
Overall Dimensions	10.2" x 5.7" x 4.8" (260mm x 121mm x 144mm)		
Window	¼" Polycarbonate		
Weight	2.6lbs (1.2kg)		

Part Numbers (Special Order Models available on request)

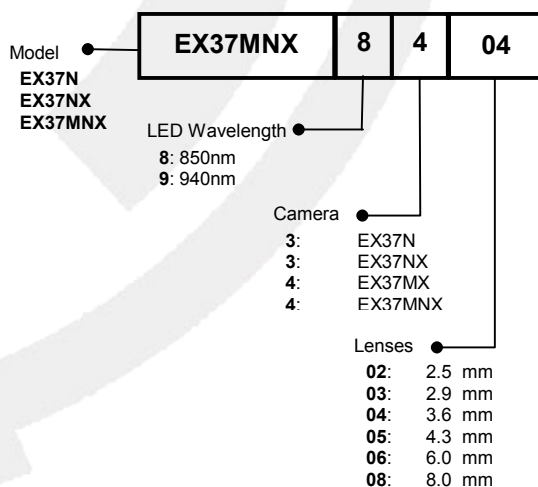
Optional Accessories

- EXAM.100** Microphone module with Pre-Amp
EXPS.008 Power supply (VAC)

Dealer / Distributor



Corporate Headquarters
Extreme CCTV Inc
 TF: 1 888 409 2288
 T: +1 604 420 7711
 F: +1 604 420 3300
 E: Sales@ExtremeCCTV.com
 www.ExtremeCCTV.com



European Operation
Derwent Systems Ltd
 A Division of Extreme CCTV (UK) Ltd
 T: +44 (0) 1670 730 187
 F: +44 (0) 1670 730 188
 E: SalesUK@DerwentCCTV.com
 www.DerwentCCTV.com