

MAIN FEATURES

Indoor/Outdoor installations

Hinged, removable body

PMMA window

Weatherproof Standard IP66/IP67

Double mounting option: regular or feed-through brackets

Very good vandal-resistant protection

DESCRIPTION

Constructed from extruded aluminium and technopolymer. Sturdy construction at a light weight, HEK offers very good vandal-resistant protection.

The opening system allows easy access for installation and servicing.

Different mounting options available: fixed (feed-through or standard) wall or ceiling mounts or P&T.

The weatherproof feature is ensured by EPDM-rubber gaskets and by 3 M16 cable glands or by the sealing rings.

A wide range of accessories is available: sunshield, heater and fan-assisted heater, blower and camera power supply. Further, it is also possible to install a blower including an air filter replacing one cable gland (not suitable in case of using the bracket with internal cable channel).

The accessories are supplied factory installed or as simple upgrade kit.



HEK30K



HEK30D (WITHOUT SUNSHIELD)



HEK30K + WB0VA2



HEK30K + WBMA

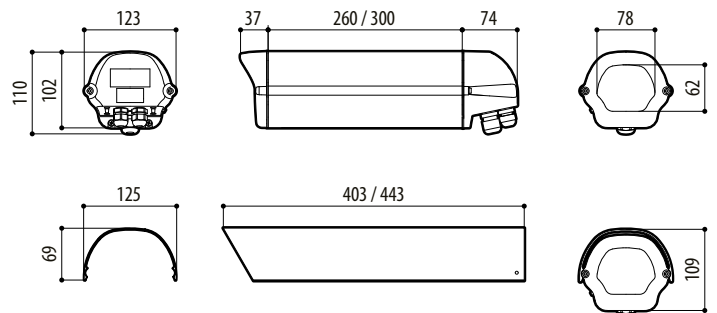

AVAILABLE MODELS					
Code	Sunshield	Heater 115/230Vac	Heater 12Vdc/24Vac	Fan assisted heater 24Vac	Max consumption
HEK26D0Y000B					
HEK26K0Y000B	•				
HEK26K1Y000B	•	•			40W
HEK26K2Y000B	•		•		20W
HEK30D0Y000B					
HEK30K0Y000B	•				
HEK30K1Y000B	•	•			40W
HEK30K2Y000B	•		•		20W
HEK30K2Y015B	•			•	24W

TECHNICAL DATA

GENERAL

Resistant technopolymer front and back cover, RAL7030
 Extruded aluminium body and external slide
 Epoxypolyester powder painting, RAL9002 colour
 Stainless steel external screws
 Supplied with instruction manual, desiccant bag, accessories for camera and lens mounting

MECHANICAL

3xM16 cable glands
 PMMA window (WxH): Ø 72mm (2.8in)
 Internal usable area (WxH): 82x62mm (3.2x2.4in)
 Internal usable length without accessories
 HEK26 260mm (10.2in)
 HEK30 300mm (11.8in)
 Internal usable length with heater and/or power supply
 HEK26 190mm (7.5in)
 HEK30 235mm (9.3in)
 Internal usable length with heater and/or blower
 HEK26 190mm (7.5in)
 HEK30 235mm (9.3in)

ELECTRICAL

Heater Ton 15°C±3°C (59°F±5°F) Toff 22°C±3°C (71°F±5°F)
 • IN 12Vdc/24Vac, consumption 20W max
 • IN 115/230Vac, consumption 40W max
 Blower with thermostat air filter, Ton 35°C±3°C (95°F±5°F) Toff 20°C±3°C (71°F±5°F) and back cover
 • IN 12Vdc, consumption 4W max
 • IN 24Vac, consumption 4W max

Not compatible with bracket with internal cable channel.

PACKAGE

Code	Unit weight		Package weight		Package dimensions (WxHxL)		Master carton
	kg	lb	kg	lb	cm	in	unit
HEK26K1	2.0	4.4	2.3	5.0	14.0x15.0x46.0	5.5x5.9x18.1	10
HEK30K1	2.2	4.8	2.4	5.3	14.0x15.0x46.0	5.5x5.9x18.1	10

Camera power supply

- IN 100-240Vac - OUT 12Vdc, 50/60 Hz, 1A
- IN 230Vac - OUT 24Vac, 50/60Hz, 400mA

ENVIRONMENT

Indoor / Outdoor
 Operating temperature with heater: -20°C / +60°C (-4°F / +140°F)

CERTIFICATIONS

CE EN61000-6-3, EN60065, EN50130-4
 IP66/IP67 EN60529 with cable glands
 IP66/IP67 EN60529 with special gaskets and bracket with internal cable channel
 IP55 EN60529 with bracket with internal cable channel

ACCESSORIES

OHEKS26A000 Sunshield for HEK26
 OHEKS30A000 Sunshield for HEK30
 OHEH02B Heater 115/230Vac
 OHEH01B Heater 12Vdc/24Vac
 OHEKVF1EB Blower with thermostat and air filter 12Vdc
 OHEKVF2EB Blower with thermostat and air filter 24Vac
 OHEPS10B Camera power supply IN 100-240Vac - OUT 12Vdc, 1A
 OHEPS11B Camera power supply IN 230Vac - OUT 24Vac, 400mA
 OWBIP2 Kit special gaskets (3xM16) to allow protection IP66/IP67 for WBOVA2 and WCM4A2 brackets
 OHEGGB Weatherproof junction box IP55

BRACKETS AND ADAPTORS

WBMA Wall bracket with ball joint
 WBOVA2 Wall bracket with internal cable channel
 WBOV3A2 Wall bracket with internal cable channel, support plate and integrated junction box
 WCM3A Ceiling bracket with ball joint
 WCM5A Ceiling bracket with ball joint
 WCM4A2 Ceiling bracket with internal cable channel
 WFWCA Column mount with ball joint

RELATED PRODUCTS

PTH300 Pan&Tilt series
 PTH900 Pan&Tilt series

SPARE PARTS

DOTHE02 Spacers for camera and lens
 OHEKMAN Cable glands, gaskets and screws kit
 OHEKFA06 Front cover RAL7030 with screws and gaskets
 OHEKFP06 Back cover RAL7030 with cable glands screws and gaskets