

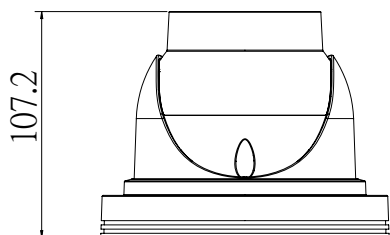

# IP CAMERA

## HS-D106N4-H

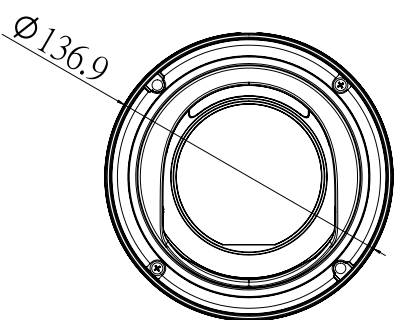

- H.265 / MJPEG
- 2MP ( 1920 × 1080 )
- 30 M IR night view distance
- 3 DNR, Digital WDR, Digital Defog
- ICR auto switch, true day / night
- Built-in micro SD card slot, up to 128GB
- Support ROI coding
- IP68 ingress protection

**RoHS** CE FC



Address: No.673, Changxing Rd., Bade Dist., Taoyuan City, Taiwan  
Website: [www.hisharp.com](http://www.hisharp.com) | E-Mail : [sales@hisharp.com.tw](mailto:sales@hisharp.com.tw)  
Tel: +886-3-3653121 | Fax: +886-3-3681482

Camera	
Image Sensor	1 / 3 " CMOS
Image Size	1920 × 1080
Electronic Shutter	1 / 10 s ~ 1 / 10,000 s
Min. Illumination	0.05 lux @F2.4, AGC ON; 0 lux with IR
Lens	VF2.8 ~ 12 mm
Horizontal view Angle	105° ~ 48°
IR Distance	30 m
Day & Night	ICR auto switch
WDR	YES
Digital Defog	YES
Digital DNR	3 DNR
Image	
Video Compression	H.265 / MJPEG
H.265 Compression Standard	Main Profile
Resolution	1080P ( 1920 × 1080 ), 360P ( 640 × 360 )
Main Stream (S1)	1080P @30fps
Sub Stream (S2)	360P @30fps
Third Stream (S3)	-
Bit Rate	100 Kbps ~ 4 Mbps
Bit Rate Type	VBR / CBR
Image Settings	White Balance, Exposure Time, Hue, Mirror, Flip, Saturation, Brightness, Contrast, Wide Dynamic, Sharpen, NR, etc. adjustable through client software or web browser
ROI	YES
Audio	
Audio Compression	G.711U
Two-way audio	YES
Interfaces	
Network	RJ45
Video Output	-
Audio line in	1 CH
Audio line out	1 CH
Alarm Input	-
Alarm Output	-



## HS-D106N4-H

Storage	
Video Format	AVI
SD card	Built-in micro SD card slot; up to 128GB
Network remote storage	YES
Functions	
Remote Monitoring	Web browsing, CMS remote control
Online Connection	Support simultaneous monitoring for up to 5 users; Support multi-stream real time transmission
Network Protocol	TCP, IP, UDP, DHCP, NTP, RTSP, DDNS, SMTP, FTP
Interface Protocol	ONVIF
Smart Alarm	Motion detection, Audio Alarm
General function	Video Setting, Camera Setting, Storage Setting, Event Setting, Network Setting, System Setting
PoE	Yes
Others	
Power Supply	DC 12V / PoE 48V
Power Consumption	< 5W
Operating Environment	- 10 ° C ~ 50 ° C ( 14° F ~ 122° F ) Humidity: less than 85 % (non-condensing)
Dimensions	Φ136.9 × 107.2 mm
Weight	Approx. 800g
Installation	Ceiling mounting (wall mounting available with the junction box and bracket)
Ingress Protection	IP68