

AMG155 1 CHANNEL INDUSTRIAL MAINS POWERED 1/2.5/5/10Gb 30/60/90W POE INJECTORS



Industrial Ethernet Solutions

AMG's industrial PoE injectors provide 30W, 60W or 90W of power injection on one 1Gb or 1/2.5/5/10Gb Ethernet port. Provided with integrated mains power input and robust surge protection as standard ensures maximum system reliability.



[AMG155 Series]

/ OVERVIEW

Designed in a compact DIN rail or wall mount housing, the AMG155 series industrial Power over Ethernet (PoE) injectors are ideally suited for providing power to remote edge network devices.

Available in both IEEE802.3at 30W or IEEE802.3bt 60/90W models they are suitable for powering the latest high powered PoE devices over a wide industrial operating temperature range.

Fitted with an integrated fully industrial mains power supply supporting either 30W, 60W or 90W PoE power.

Designed as standard single channel injectors supporting 1Gb Ethernet or 1/2.5/5/10Gb Ethernet depending on the model selected.

Robust surge protection ensures maximum operating reliability and the highest levels of performance.

A wide range of models are available to suit all design requirements.

/ FEATURES

- Compact size – ideal for confined spaces, including camera poles and roadside cabinets
- -40°C to +75°C temperature maintains performance in extreme conditions
- Plug & Play – no need for any user configuration
- DIN rail mountable – quick to install and remove for maintenance
- RJ45 ports support 1Gb or 1/2.5/5/10Gb speeds
- Integrated mains power supply with 52V_{DC} @ 30W, 52V_{DC} @ 60W or 54V_{DC} @ 90W output
- Supports 15W, 30W, 60W, and 90W PoE
- Integrated surge protection with up to 20kA discharge capability for maximum protection in harsh environments
- Designed in the USA & UK. Manufactured in the United Kingdom
- AMG Lifetime Support Warranty

Specifications.

Standards.

IEEE802.3i	10Base-T
IEEE802.3u	100Base-TX
IEEE802.3ab	1000Base-T
IEEE802.3bz	2.5/5GBase-T
IEEE802.3an	10GBase-T
IEEE802.3af	15W PoE
IEEE802.3at	30W PoE+
IEEE802.3bt	60 & 90W PoE
Jumbo Frames	Transparent to Jumbo Frames
VLAN Support	Transparent to VLAN traffic
Multicast Support	Transparent to Multicast traffic

Interface.

LED Indicators	Power PoE
RJ45 Ports	2x 10/100/1000T(X) RJ45 or 2x 100/1000/2.5G/5G/10G RJ45 with 2 kV Isolation Protection
Mains Power	1x IEC C14 Socket with locking security bracket

Power.

Power Inputs	1
Input Voltage	85-264V _{AC} or 120-370V _{DC}
Input Frequency	47-63 Hz
Input Current	2A (115V _{AC}) / 1A (230V _{AC})
Power Consumption	2W Max (without PoE Load)
Integrated PSU Type:	52V _{DC} @ 30W 52V _{DC} @ 60W (Refer to derating chart) 54V _{DC} @ 90W (Refer to derating chart)
PSE Modes	Mode A, Mode B
Protection	Overload Current

Packaging.

Shipping Weight	1.03kg / 2.27lb
Dimensions:	(W x D x H) 220 x 170 x 80 mm 8.66 x 6.69 x 3.15 in

Surge Protection*.

AC Surge Protection:	
Line-Earth	±4KV _{1.2/50µs (8/20µs)}
Line-Line	±2KV _{1.2/50µs (8/20µs)}
RJ45/PoE Surge Protection:	
Technology	GDT
Nominal Line Voltage	48-57V _{DC}
Max DC Voltage	75V _{DC}
Protection Level	75V _{DC} (C3 Category Line/Line)
Impulse Current	2kA (D1 Category 10/350µs x 1)
Line/Line Nominal	
Discharge Current	2kA (C2 Category)
Line/Earth Nominal	
Discharge Current	10kA (C2 Category 8/20µs x 10)
IEC 61000-4-5 (Surge)	20kA (8/20µs x 1)
Pinout	(1-2)(3-6)(4-5)(7-8)
Failsafe Mode	Short-Circuit / Cut-Off
Disconnect Indicator	Transmission Interrupt

*Earth must be connected for protection

Mechanical.

Housing	Anodised Aluminium
Dimensions:	(W x D x H) 65 x 88 x 107 mm 2.56 x 3.46 x 4.21 in
(Excluding Wall Brackets)	
IP Rating	IP40
Installation	Wall Mount or DIN-Rail
Weight	0.66kg / 1.46lb

Environmental.

Operating Temp.	-40 to +75°C / -40 to +167°F
Storage Temp.	-40 to +85°C / -40 to +185°F
Humidity	5% to 95% (non-condensing)
MTBF	>300,000 hours
MTBF Standard	MIL-HDBK-217F GF 25°C
Heat Dissipation	109 BTU/h (30W PoE) 212 BTU/h (60W PoE) 331 BTU/h (95W PoE)
Cooling	Passive Cooling
Noise Level	0 dBA

Specifications.

Regulatory.		EN 61000-4-11 (Dips)
Safety	EN 62368-1 Class I	IEC 60068-2-27
EMI	EN 55032 Class B CISPR 32	IEC 60068-2-32
EMS	FCC Part 15B Class B	IEC 60068-2-6
	EN 61000-4-2 (ESD)	IEC/EN 61643-21
	EN 61000-4-3 (RS)	Reach
	EN 61000-4-4 (EFT)	RoHS
	EN 61000-4-5 (Surge)	WEEE
	EN 61000-4-6 (CS)	NDA & TAA Compliant
		Supply Chain
		Designed to meet NEMA TS2 & EN 50121-4

Application Diagram.

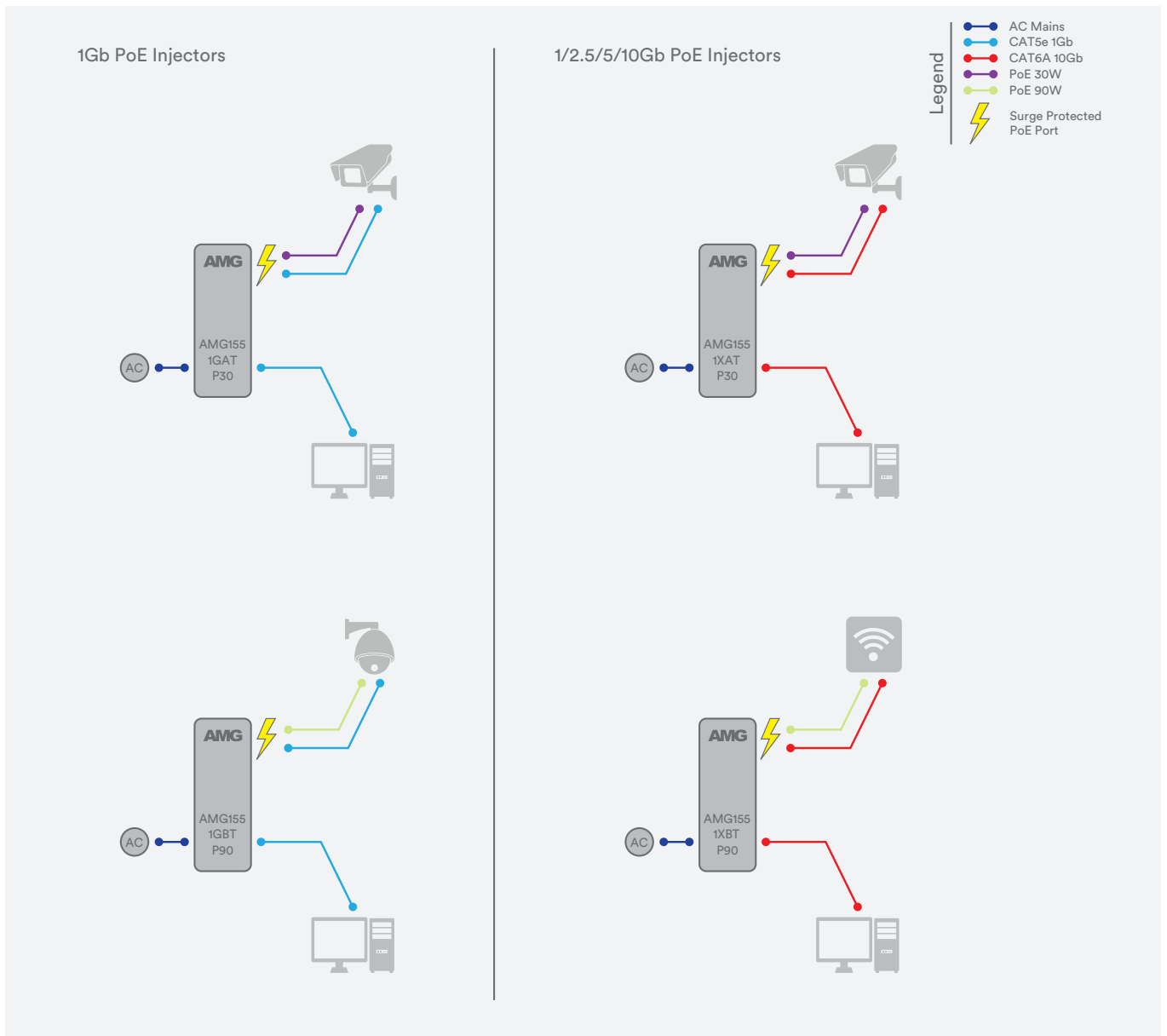

Product Characteristic Curve.

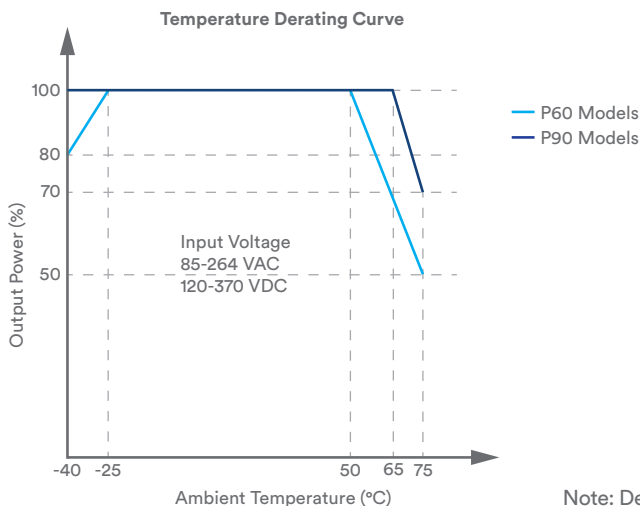

Note: Derating Chart Applies To 60 & 90W Models Only

Part Numbers.

1Gb Industrial PoE Injectors With Integrated Mains PSU

AMG155-1GAT-P30	Industrial 1 Port PoE Injector, 1 × 10/100/1000Base-T(x) RJ45 Port (Input), 1 × 10/100/1000Base-T(x) RJ45 Port With 802.3at 30W PoE+ (Output), 30W PSU
AMG155-1GBT-P60	Industrial 1 Port PoE Injector, 1 × 10/100/1000Base-T(x) RJ45 Port (Input), 1 × 10/100/1000Base-T(x) RJ45 Port With 802.3bt 60W PoE (Output), 60W PSU
AMG155-1GBT-P90	Industrial 1 Port PoE Injector, 1 × 10/100/1000Base-T(x) RJ45 Port (Input), 1 × 10/100/1000Base-T(x) RJ45 Port With 802.3bt 90W PoE (Output), 90W PSU

1/2.5/5/10Gb Industrial PoE Injectors With Integrated Mains PSU

AMG155-1XAT-P30	Industrial 1 Port PoE Injector, 1 × 10/100/1000/2.5G/5G/10GBase-T(x) RJ45 Port (Input), 1 × 10/100/1000/2.5G/5G/10GBase-T(x) RJ45 Port 802.3at 30W PoE+ (Output), 30W PSU
AMG155-1XBT-P90	Industrial 1 Port PoE Injector, 1 × 10/100/1000/2.5G/5G/10GBase-T(x) RJ45 Port (Input), 1 × 10/100/1000/2.5G/5G/10GBase-T(x) RJ45 Port 802.3bt 60/90W PoE (Output), 90W PSU

Included Accessories.

DIN Rail Adapter	Rear Mounted Metal DIN Rail Clip & Screws For DIN Rail Mounting AMG155 Series Products
Wall Mounting Brackets	2x Wall Mounting Brackets & Screws For Wall / Surface Mounting AMG155 Series Products
IEC Plug Locking Bracket	Angled Locking Bracket & Screws To Secure The Included Left Angle IEC Line Cord
Left Angle IEC Cable	Region Specific UK/EU/US Left Angled IEC Line Cord

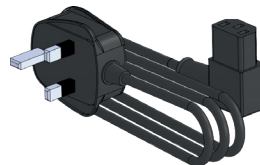
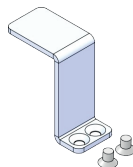
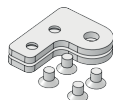
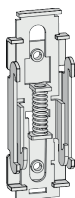

Optional Accessories.

AMG2035	Side Mounted Wall Bracket Adapter Kit For DIN Rail Mounting AMG155 Series Products In Depth Restricted Installations. Adapter Kit Can Be Extended Using The Included Extension Kit To Also Mount A DIN Rail Power Supply Up To 480W
---------	---

In a continuing effort to improve and advance technology, product specifications are subject to change without notice. Please visit www.amgsystems.com for the latest product specifications.

Proud to be a British
Manufacturer 