

G-COMIN

TL-600

**SINGLE-PERSON OPERATED
BATTERY-POWERED
MOBILE LIGHT TOWER**



View Actual
Product Video

SHENZHEN COMING TECHNOLOGY CO., LTD

+86-755-28462760

Shenzhen, China

www.co-ming.com

info@co-ming.com



Now Entering The Battery Era



TL-600
Battery Powered
Mobile Light Tower



Traditional
Diesel Light Tower



**0dB Quiet
Operation**



Noise
Hearing Damage



**0 Diesel
Cost**



Fuel
Continuous Cost
Increases



**0 Carbon
Emissions**



Fumes
Health Threat



**0 Maintenance
Cost**

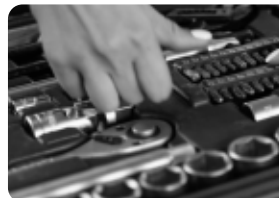

Maintenance
Frequent & Tedious



**0 Trailer
Cost**



Transportation
Costly & Inefficient

A **Smarter** Alternative to Diesel Light Towers



82Kg-Class Single-Person
Rapid Deployment



LFP Battery Powered
Versatile For Various Sites



All-Terrain Wheels +
Stabilizing Outriggers

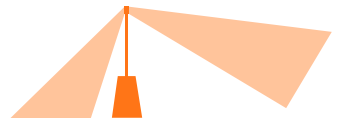

360° Horizontal + 270°
Vertical Per Lamp Head



IP65 Weatherproof
Wind Resistance Level 8



Narrow, Wide and Medium Beam
Angles for Different Lighting Areas



Maximum Output Up To **105,000 LM**

3 Brightness Levels

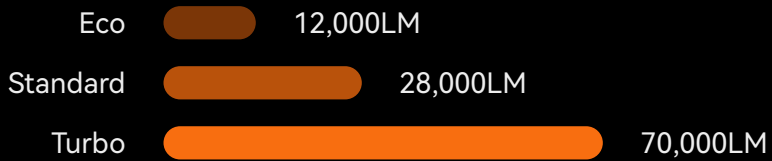

Boost Mode



Switch beam angle with one click

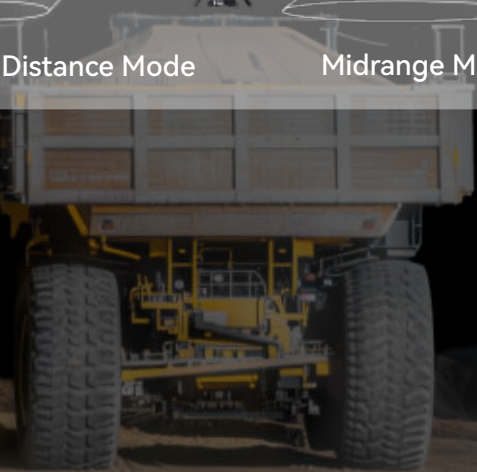
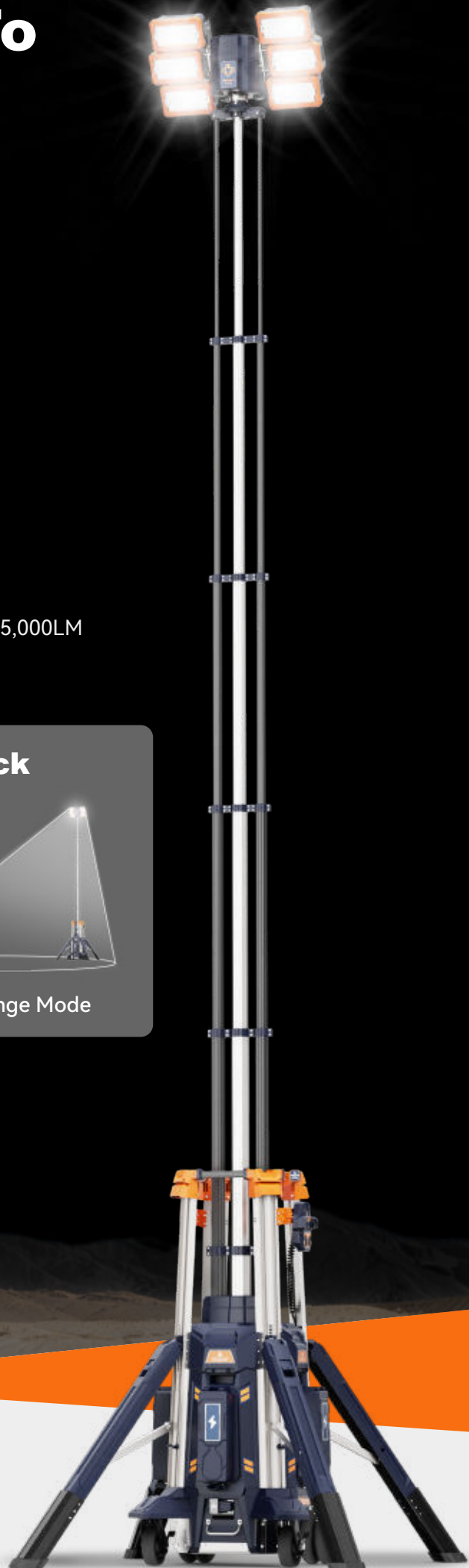

Typical Working Hours (3 x D70-1000)

10 - 70 HOURS

(Turbo)

(Eco)



**Battery
Power**



**Mains
Power**



D70-1000 (7.1Kg)

Max 3 interchangeable
batteries at once



XVE550 (1.9Kg)

Power light tower
& charge its batteries



Intelligent Lighting Control

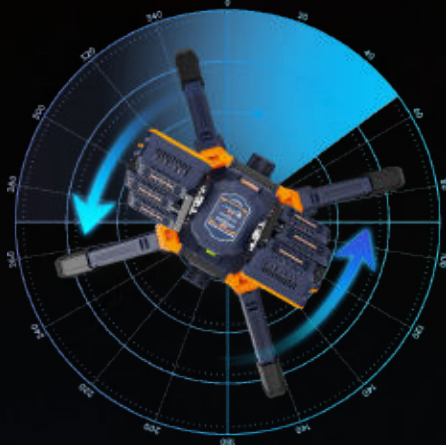

Patrol Mode

Unique automatic 360° patrol mode

360° Horizontal Rotation



270° Vertical Rotation



Independent left & right module rotation



All-Weather Available

IP65 Waterproof



Sandy

Sand & dust resistant



Rainy

IP65 waterproof



Scorching

UV & Heat resistance



Snowy

Operating temperature
down to -15°C



Corrosive

Coastal corrosion resistant



Windy

60km/h Wind resistance



Humanized Design Hidden In The Details

Warning Light Slots



Grip & Lift Handle



Easy Control & Storage

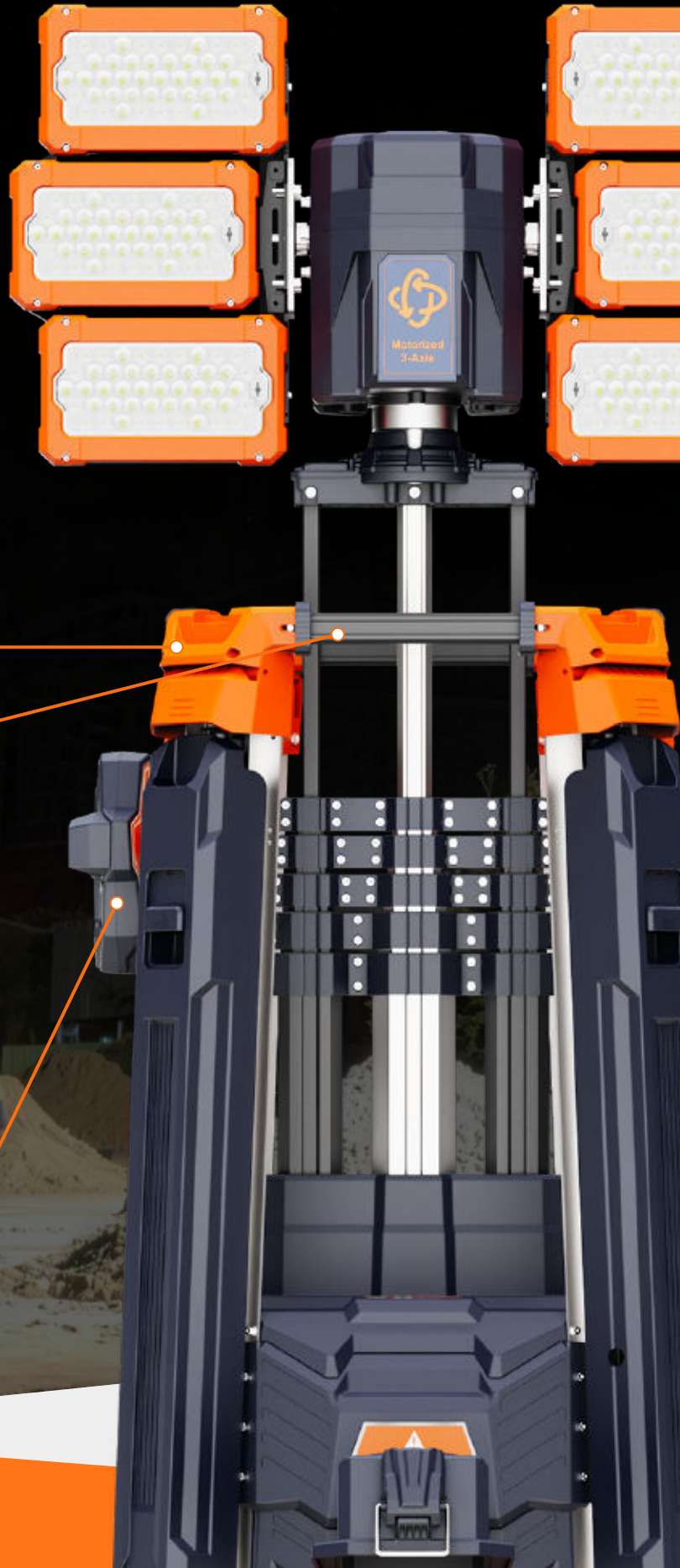
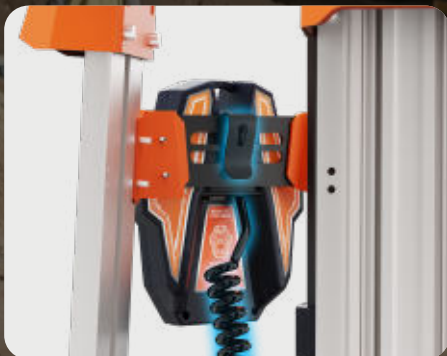

Waterproof Toolbox



Power Switch

One-button battery power-off

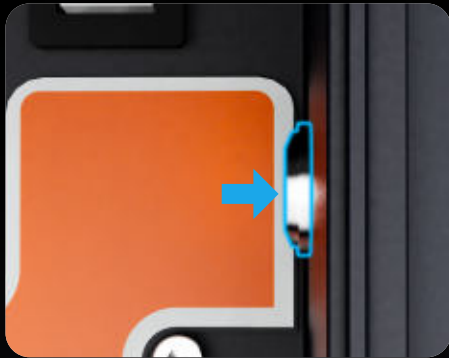

Manual Emergency Retract

Dual-clutch design

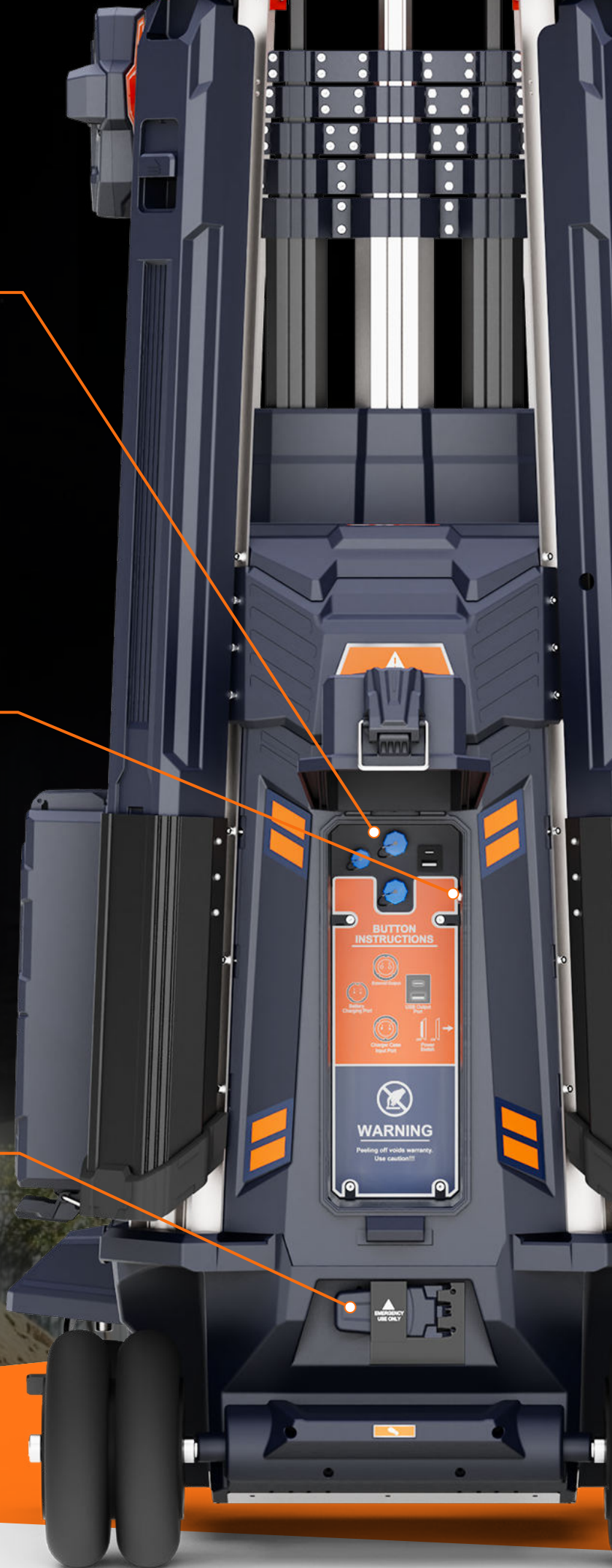

All-Terrain Wheels & Stabilizing Outriggers

Quick Release Unlock



Multi-Level Self-Locking Support Legs



Dual-Axis Level

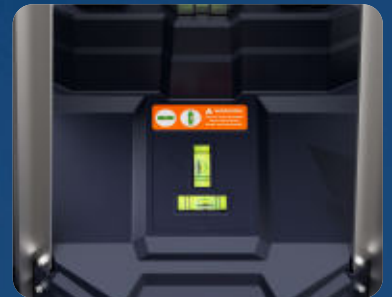

Swivel Casters with Brakes

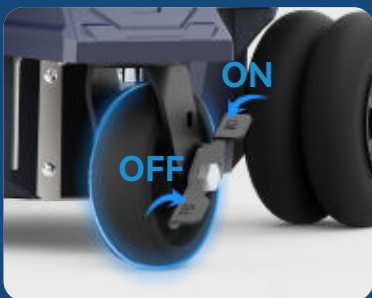

Large Rear Wheels



Optional Accessories



Battery (D70-1000)



Backup Case (TKC-3)



Solar Panel (FS2-150)

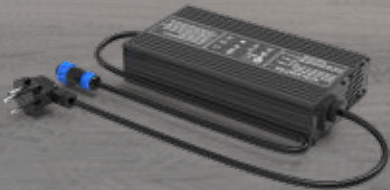

Adapter (XVE550)



Flash Light (S3)



Lighting **Wherever** **You Need It**



Construction



Mining



Emergency



Power Grid



Firefighting



Maintenance



Events



Sports



Oil & Gas

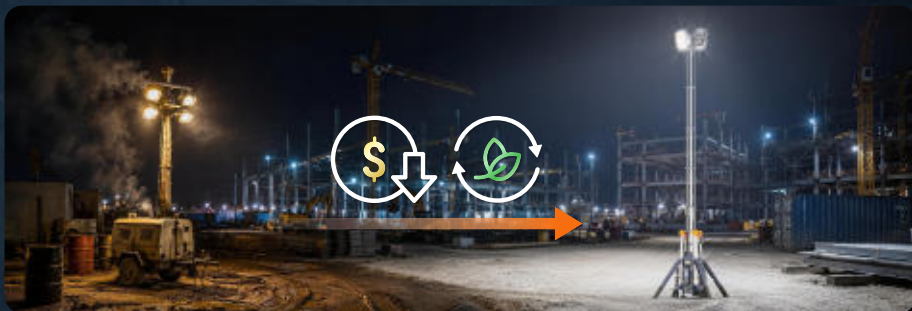

Energy-Saving Upgrade for Traditional Light Towers



6.0m

Parameters

TL-600

General Specifications

Height	1.6~6.0m
Weight	82.0KG (Fitting only)
Power Supply	AC Power / Battery Power / Internal Battery / Solar Power
IP Grade	IP65
Input Voltage	DC 70.4V (Battery) / DC 80.4V (Adapter)
Output(USB)	Type-A (5V 2A) & Type-C (5V 2A)
Rotation Angles	360° Horizontal + 270° Vertical Per Lamp Head
Working Temp	-15°C-50°C

Battery Power

Brightness Levels	Lumens	Run Times (3 x D70-1000)
Eco	12000LM	70H
Standard	28000LM	22H
Turbo	70000LM	10H
Boost	105000LM	-

Package

Model	TL-600
Size of Carton	690*720*1750 mm
Gross Weight of Carton	100Kg
PCS/Carton	1

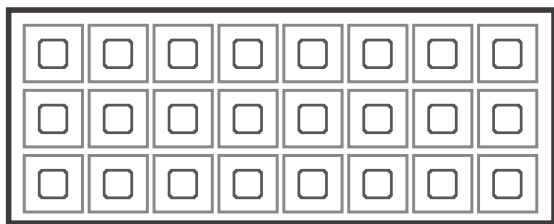
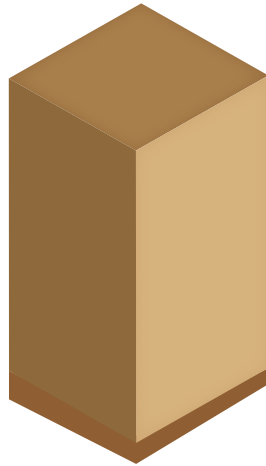

20GP Container **24 Unit**

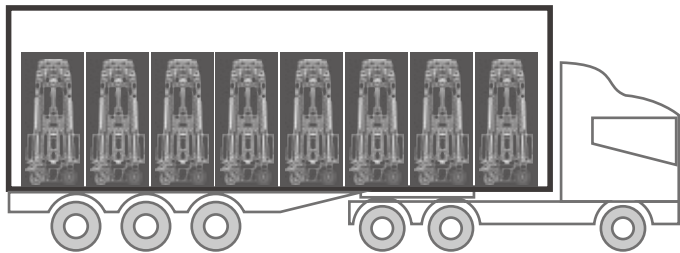

40GP Container **48 Unit**

Size (mm)

